

## REMARKS

Claims 1 - 30 remain active in this application. Claims 11, 13 and 16 - 30 have been withdrawn from consideration as being non-elected, with traverse, in response to a requirement for restriction. The specification has been reviewed and editorial revisions made where seen to be appropriate. No new matter has been introduced into the application. The indication of allowability of 6, 8, 9, 14 and 15 is noted with appreciation.

The Examiner has maintained the requirements for restriction and election of species. The traverse of these requirements is, however, also respectfully maintained since it is respectfully submitted that classification is not, in and of itself, determinative of distinctness or independence of inventions or the existence of a serious burden of examination. The Examiner has not indicated any search area for the non-elected inventions where no relevant art would be expected in regard to the elected invention. Therefore, it is again respectfully submitted that neither independence or distinctness of the identified inventions or the existence of a serious burden of examination has been *prima facie* demonstrated and reconsideration and withdrawal of these requirements are respectfully requested.

The Examiner has objected to the drawings and the specification due to reference numerals in the specification but not the drawings and vice-versa. These objections are respectfully traversed; some as being in error and some as being moot in view of the above amendments to the specification and proposed revisions of the drawings.

Specifically, the specification has been amended to clearly indicate that reference numeral 320 appears in Figure 3 but not necessarily Figure 1 where the air passages are depicted more generally. Also, as to reference numeral 310, the Examiner's attention is respectfully called to page 15, lines 21 - 22, where it is explicitly recited that the "transport or translation table" is "schematically illustrated by double arrow 310". Therefore, there is no inconsistency between the language of the specification and the depictions of the drawings as the Examiner asserts. Otherwise, all of the Examiner's criticisms have been fully answered by the above amendments to the specification or the drawings. Accordingly, it is respectfully requested that these objections be reconsidered and withdrawn.

The Examiner has further objected to the specification in regard to certain enumerated possible errors. This objection is respectfully traversed as moot in view of the amendments made above. Each of the Examiner's criticisms has been fully answer, adopting the Examiner's suggestions in all but one instance. Specifically, the Examiner suggests substituting "2A" for "2B" at page 9, line 3. However, the import of the sentence at that location concerns the provision of clamp arrangements at the periphery of the object to be secured; which periphery is possibly *least* well-illustrated in Figures 1 and 2A of the Figures mentioned while Figures 1 and 2B were indicated as exemplary of illustration of that subject matter. Thus "2A - 2C" has been substituted for "2B".

Claims 1 - 5, 10 and 12 have been rejected under 35 U.S.C. §102 as being anticipated by Shioya et al. This sole ground of rejection is respectfully traversed since the Examiner seeks to read the claimed elements on

structure in Shioya et al. which do not answer the recitations of the claims.

Specifically, The Examiner seeks to read the structure recited in claim 1 on the Shioya reference as follows:

"a clamp structure" is read on "holder device" or "cap" 40 of Shioya et al. which merely positions "first part 10" in an engaging hole 53 and which has no moving parts or function as a "clamp" in any way;

"a first actuator" is read on "housing" 42 of Shioya et al. which is an entirely passive structure which does not even contact "first part" 10, much less applying a first clamping force to an object;

"means for producing a signal corresponding to acceleration of an assembly of said object and said surface" is read on "pressure sensor" 92 of Shioya et al. which has nothing whatsoever to do with acceleration or producing a signal corresponding to any movement: and

"a second actuator" is read on "thrust force applying device" 58 of Shioya et al. which appears (see column 7) to be the entire assembly which applies pneumatic pressure to "second part" 12 to drive it toward "first part" 10 and has nothing to do with applying a "clamping force" to anything, much less a force "corresponding to said acceleration".

In short, Shioya et al. is directed to a method and apparatus for causing an interference fit between two parts and has nothing at all to do with holding parts together with a substantially minimized clamping force which can be selectively increased to a desired and variable degree in accordance with accelerations detected or predicted. Shioya et al. merely senses pneumatic pressure and prevents driving the second part 12 toward first part 10 until the pneumatic pressure is sufficient

to adequately accelerate the second part to achieve the desired interference fit. The most that can be said for Shioya et al. is that it may, trivially, produce an acceleration corresponding to a pressure but is thus diametrically opposed to the concept of the invention which produces a clamping force corresponding to an acceleration. Further, as pointed out above, the functional portions thereof identified by the Examiner do not, in fact, correspond to the respective elements claimed in combination in independent claim 1. The Examiner appears to have completely ignored both the nomenclature and recited functions of every recited claim element. Therefore, it is respectfully submitted that Shioya et al. does not, in fact or even arguably, anticipate any claim in the application and a *prima facie* demonstration of anticipation (or even obviousness) has not been and cannot be made based on Shioya et al. Accordingly, it is respectfully requested that this sole ground of rejection be reconsidered and withdrawn.

Since all rejections, objections and requirements contained in the outstanding official action have been fully answered and shown to be in error and/or inapplicable to the present claims, it is respectfully submitted that reconsideration is now in order under the provisions of 37 C.F.R. §1.111(b) and such reconsideration is respectfully requested. Upon reconsideration, it is also respectfully submitted that this application is in condition for allowance and such action is therefore respectfully requested.

A petition for an extension of time has been made above. If any further extension of time is required for this response to be considered as being timely filed, a conditional petition is hereby made for such extension of time. Please charge any deficiencies in fees and credit

any overpayment of fees to Attorney's Deposit Account No.  
50-2041.

Respectfully submitted,

A handwritten signature in cursive script that reads "Marshall M. Curtis".

Marshall M. Curtis  
Reg. No. 33,138

Whitham, Curtis, Christofferson & Cook, P. C.  
11491 Sunset Hills Road, Suite 340  
Reston, Virginia 20190

(703) 787-9400  
Customer Number: **30743**

# Annotated Marked-Up Drawings

Title of Invention: Acceleration Clamp Assist  
 Inventor's Name: MARGESON, C.S.  
 Docket No./Application No.: 10/807,291

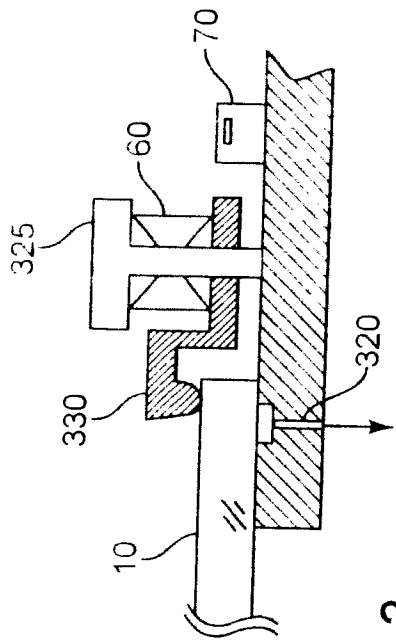

Figure 3

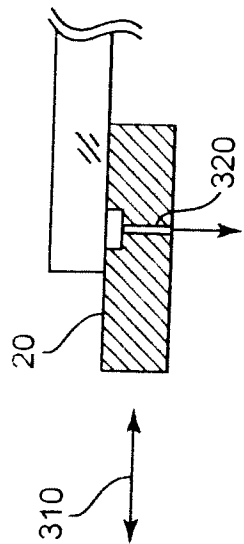

Figure 3A

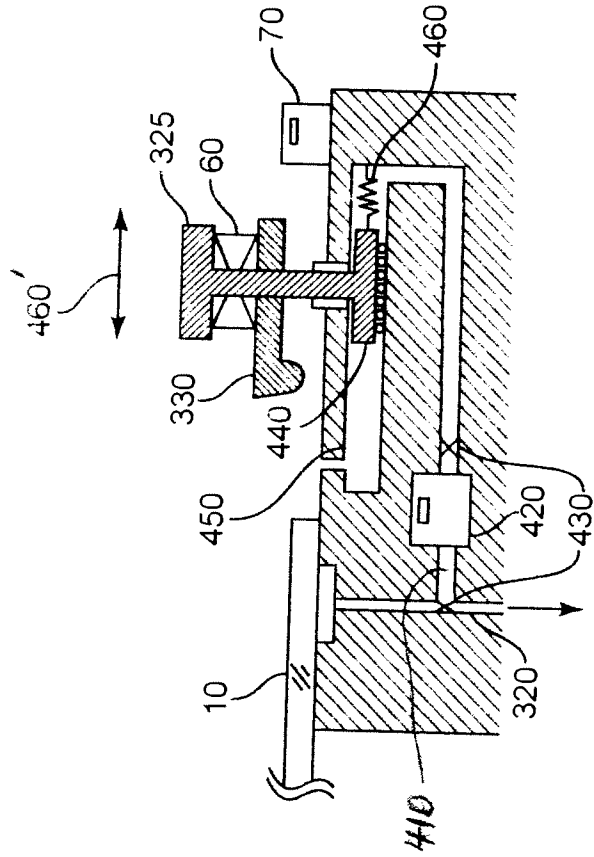
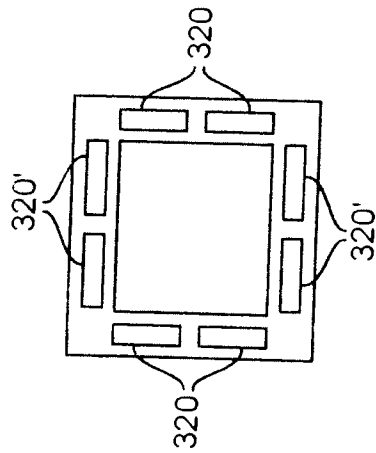

Figure 4



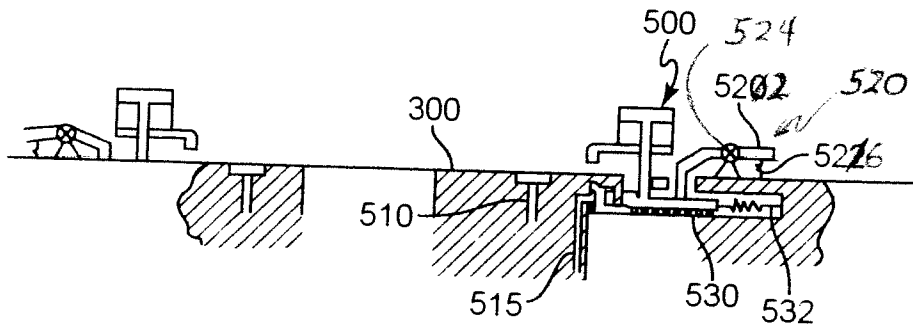

Figure 5

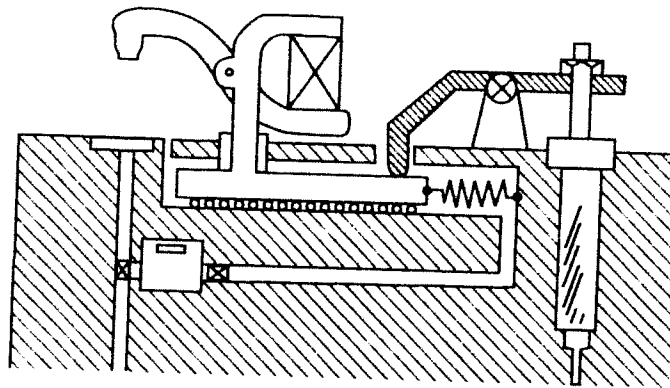

Figure 5A

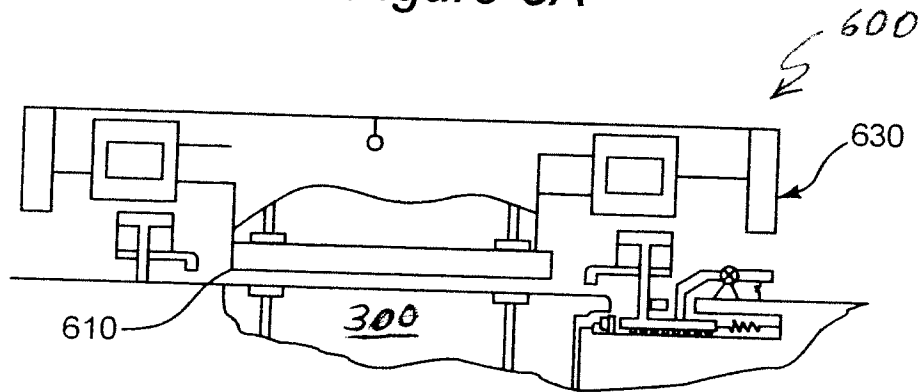

Figure 6

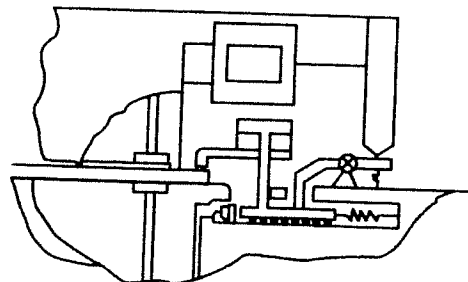

Figure 7